

CM6032V201R-10

UNCONTROLLED DOCUMENT

PHYSICAL DIMENSIONS:

A	15.24	[.600]	± 0.23	[.009]
B	8.13	[.320]	± 0.13	[.005]
B ₁	10.92	[.430]		MAX
C	9.45	[.372]	± 0.15	[.006]
C ₁	10.08	[.397]		MAX
D	4.06	[.160]	± 0.05	[.002]
E	1.27	[.050]	± 0.13	[.005]
E ₁	2.03	[.080]	± 0.13	[.005]

WIRE DIMENSIONS:

T ₁	3.30	[.130]	± 0.38	[.015]
T ₂	0.64	[.025]		TYP
T ₃	0.38	[.015]		TYP

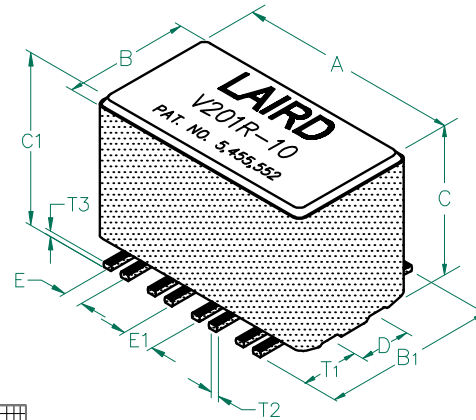

ELECTRICAL CHARACTERISTICS:

Z @ 100MHz (Ω)	DCR (Ω)	Rated Current
Nominal	200	
Minimum	150	
Maximum	250	8,000 mA

NOTES: UNLESS OTHERWISE SPECIFIED

1. TAPED AND REELED per CURRENT EIA SPECIFICATIONS 13" REELS, 250 PCS/REEL.
2. COMPONENTS SHOULD BE ADEQUATELY PREHEATED BEFORE SOLDERING.
3. REF. CARRIER TAPE SPECIFICATION # CART6032-23.
4. TERMINATION FINISH IS 100% TIN.
5. THIS PART HAS NO PIN POLARITY.

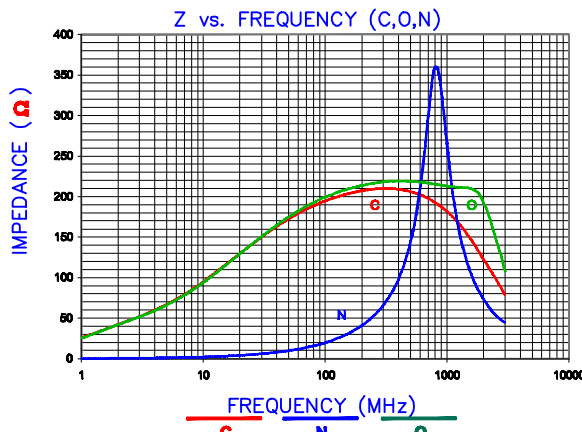

Z, R, XL vs. FREQUENCY

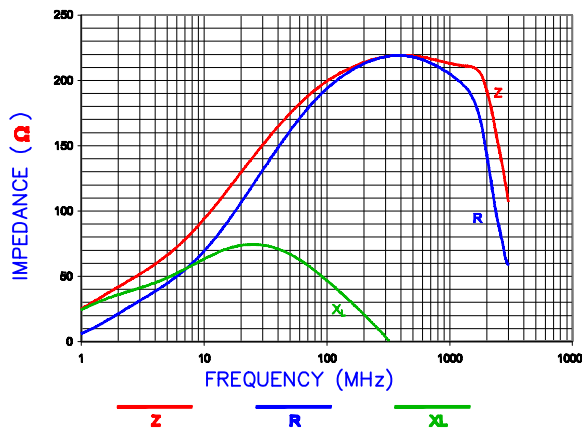

LAND PATTERNS FOR REFLOW SOLDERING

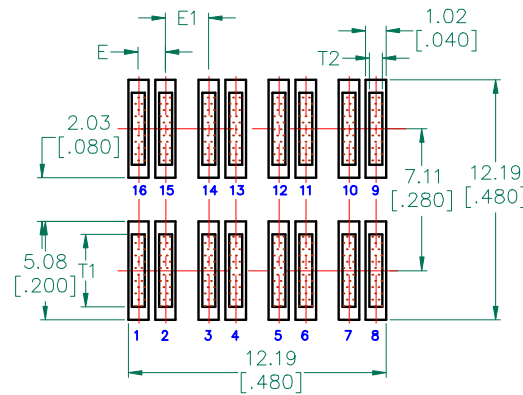

RECOMMENDED SOLDERING CONDITIONS

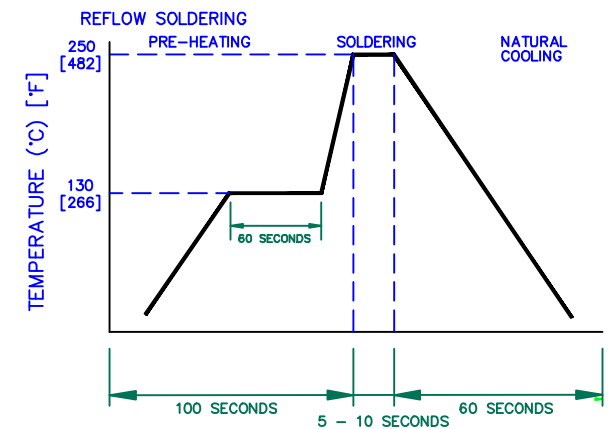

EQUIVALENT CIRCUIT

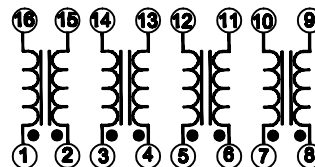

DIMENSIONS ARE IN mm [INCHES]				This print is the property of Laird Tech. and is loaned in confidence subject to return upon request and with the understanding that no copies shall be made without the written consent of Laird Tech. All rights to design or invention are reserved.			
D	UPDATE COMPANY LOGO & KAPTON LABEL ADD EQUIV. CIRCUIT	11/12/08	JRK	PROJECT/PART NUMBER: CM6032V201R-10	REV	D	DRAWN BY: JRK
C	UPDATE COMPANY LOGO	01/08/08	JRK		SHEET:		
B	CORRECT REV BLOCK mm [INCHES]	10/20/06	JRK	DATE: 06/11/04	SCALE: NTS		
A	ORIGINAL DRAFT	06/11/04	JRK	CAD #	TOOL #		
REV	DESCRIPTION	DATE	JRK	CM6032V201R-10-D-2	H0600-200		2 of 3

